

HALL EFFECT TECHNOLOGY JOYSTICK

The JH Series Joystick is designed around the rugged mechanism of a traditional 4-way hydraulic joystick, but it utilizes contactless Hall Effect technology for increased life and more dependable performance in the field. This combination provides performance and features never before available in an electronic joystick. The JH series uses OTTO's field-proven dual magnet configuration found in OTTO's HPL Linear Output Hall Effect switches. The Hall Effect sensors are fully protected against electromagnetic and radio frequency interference (EMI and RFI) up to 100 volts per meter. Programmable sensors with built-in magnetic temperature compensation logic ensure consistent and repeatable operation. The JH series is designed for maximum flexibility in features and in tactile feel. A wide variety of input and output configurations are available to satisfy different applications. The modular electronic package can be configured for both standard and custom I/O requirements including CANbus and other output options available.

Features:

- Adapts to a wide variety of shaft styles
- 15 million cycle life in all directions
- 300lb. static load strength at grip
- Electronics sealed to IP68S
- EMI/RFI shielding up to 100V/M
- Factory programmable pretravel & overtravel
- Analog, CANbus, USB & other custom output options available
- Redundant outputs available
- Fail safe & neutral indicator
- Single or dual axis available



JH Joystick shown with OTTO Medium Universal Grip, K1 Rocker and P3 Pushbutton switches.

HALL EFFECT TECHNOLOGY JOYSTICK

Standard Characteristics/Ratings:

GENERAL:

Sensor Type: Hall Effect analog, 1 or 2 outputs per axis

Design: Dual magnet

ELECTRICAL RATINGS: 1.0-4.0V Rated at Vcc = 5V @ 20°C Load = 1mA (4-7kΩ)

Electrical	Units	Min	Typ	Max
Supply Voltage	VDC	4.5	5.0	5.5
Output Voltage 0°-2° Deflection Tolerance at Center	VDC @ 5V Vcc	-0.15	N/A	+0.15
Output Voltage 19°-20° Deflection Tolerance at Full Load	VDC @ 5V Vcc	-0.15	N/A	+0.15
Supply Current Per Sensor	mA	N/A	N/A	10.0
Output Source Current Limit	mA	-1.0	N/A	1.0

MECHANICAL:

Mechanical Life: 15,000,000 cycles in all directions

Travel Angle: 20° typical

Overtravel Angle: 0.5° min to 1.5° max

Operating Force: With bellows, 20°C to 85°C at grip, 3.5lbs. min to 5.5lbs. max
With bellows, -40°C at grip, 13.0lbs. min to 18.0lbs. max

ENVIRONMENTAL:

Operating Temp Range: -40°C to +85°C

Storage Temp Range: -65°C to +105°C

Drop: 1 foot max to concrete

Humidity: 96% RH, 70°C, 96 hours

Vibration: 10g., 10Hz to 2KHz swept sinusoidal

Electronics: Sealed to IP68S

RFI: Withstand 100V/M, 14 KHz to 1GHz

EMI: Withstand per MIL-STD-461D/SAE J1113-22

Sand/Dust: Without bellows, withstand per SAE J1455

MATERIALS:

Housing: Polyester

Bellows: Neoprene, black

Cable: 22 AWG (19 strands of 34 AWG TSC)

Mounting Hardware: 1/4-20 x 3/4 carriage bolts, self-locking nuts

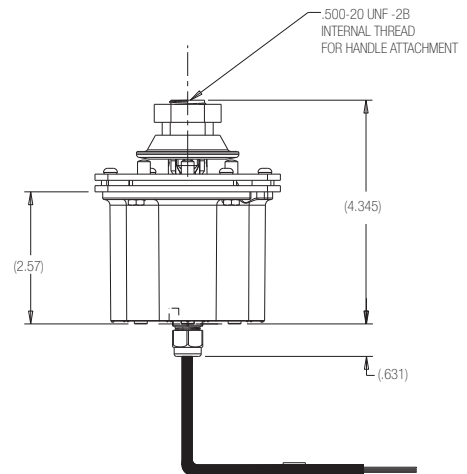
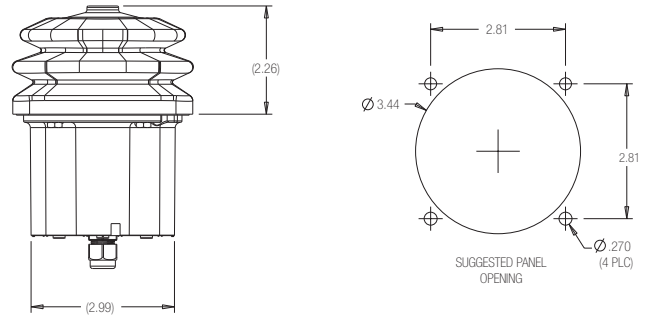

Hall Joystick

CAN CABLE	
POWER	1 - RED
GROUND	2 - BLACK
ADDRESS RESISTOR	3 - GREEN
ADDRESS RETURN	4 - BLUE
CAN HIGH	5 - YELLOW
CAN LOW	6 - BROWN
NC	7 - NONE
SHIELD	8 - DRAIN

I/O CABLE	
DIGITAL GROUND	1 - BLACK
SWITCH 1	2 - BLUE
SWITCH 2	3 - ORANGE
SWITCH 3	4 - VIOLET
SWITCH 4	5 - WHITE/RED
SWITCH 5	6 - GRAY
SWITCH 6	7 - WHITE/BLUE
SWITCH 7	8 - WHITE/GREEN
SWITCH 8	9 - WHITE/BLACK
SWITCH 9	10 - WHITE/ORANGE
SWITCH 10	11 - BROWN
+5 VDC	12 - RED
ANALOG IN 1	13 - YELLOW
ANALOG IN 2	14 - GREEN
ANALOG GROUND	15 - WHITE
SHIELD	16 - DRAIN

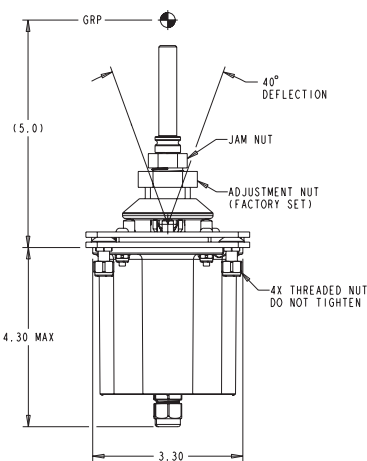

CANbus Technology Joystick

