

# Penny+Giles Ergonomic Handles

This brochure details Penny & Giles' current range of ergonomic handles that complement their extensive range of electronic joysticks. It should be read in conjunction with their joystick brochure, which can be supplied on request.

The functionality and size of each handle has been specified for finger, palm or hand operation. The layout and

operating force of all switches, potentiometers or membrane keypads minimise both the amount of finger movement and the effort needed to activate each operation. The subsequent reduction in the mental and physical effort required to operate your machine can help to increase its productivity.

Handle	Compatible with				Functionality				
	JC150	JC300	JC400	JC600	Switches (Maximum Number)			Z Axis (Action)	Deadman's
					Momentary	Rocker	Membrane		
CL	✓			✓					JC600 only
EL	✓								
HB	✓			✓	✓ 1	✓ 1			✓
HC	✓			✓	✓ 6		✓		
HP	✓			✓	✓ 4			✓ Push	
HS	✓			✓	✓ 6				
WT	✓			✓		✓ 4			✓
WN	✓			✓		✓ 4			
A	✓			✓	✓ 8	✓ 2		✓ Rocker	✓
TR	✓			✓	✓ 3				
ZA		✓	✓					✓ Rotary	
ZAS		✓	✓					✓ Rotary	
ZC		✓	✓						
ZCS		✓	✓		✓ 1				✓
KW		✓	✓						
KWS		✓	✓		✓ 1				✓

## CL/EL HANDLE OPTIONS



CL or EL handle options

Developed to improve the integrity of your control system, the Center Lock (CL) and End Lock (EL) range of handles, mechanically hold the shaft of the JC150 or JC600 in its safe central position or at either end of the JC150's range of travel. Lifting a collar at the base of the handle, unlocks the shaft.

A micro-switch in the JC600 variant of the CL handle is activated when the collar is lifted. Such a signal could be used, for example, to increase the speed of your hydraulic pump.

Note: This handle option is not available with the L (Light) option Center Return Spring with the JC600

Specification	CL	CL	EL
Joystick Range	JC600	JC150	JC150
Maximum Height Above Flange	110mm	110mm	110mm
Maximum Diameter	41mm	41mm	41mm
Environmental Sealing (BSEN60529)	IP65	IP65	IP65
No of Switches	1	0	0
Action	Microswitch		
Maximum Current @ 24Vdc	0.1A		
Expected Life (Operations)	1,000,000		

Termination Details	CL
Joystick	JC600
Common Terminal Switch 1	2
N/O Contact Switch 1	16

**Note:** JC600 signals terminate on the 16 pin connector

## HB HANDLE OPTIONS



HB2 handle option

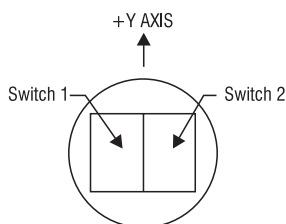

ROCKER ORIENTATION AND SWITCH IDENTIFICATION

Developed to replicate the functionality of the traditional mechanical handle, the HB range of hand grips can be specified with either a button or rocker switch, mounted into the

top of the handle, within easy reach of the operator's thumb. These can be configured as a Deadman's feature or, for example, the steer signal for an access platform.

Specification	HB0	HB1	HB2	HBD
Joystick Range	JC150, JC600	JC150, JC600	JC150, JC600	JC150, JC600
Maximum Height Above Flange	149mm	155mm	155mm	164mm
Maximum Grip Diameter	35mm	35mm	35mm	35mm
Environmental Sealing (BSEN 60529)	IP65	IP65	IP65	IP65
Number of Switches	0	1	2	1
Action		Momentary Rocker	Momentary Rocker	Momentary Button
Switch Operating Force				7N
Maximum Current @ 30Vdc		2.5A	2.5A	5A
Expected Life (Operations)		100,000	100,000	100,000

Termination Details	HB1		HB2		HBD	
Joystick	JC150	JC600	JC150	JC600	JC150	JC600
Common Terminal	16	11	16	11	16	11
N/O Contact Switch 1	6	4	6	4	3	1
N/C Contact Switch 1	3	1				
N/O Contact Switch 2			3	1		

**Note:** JC600 signals terminate on the 12 pin connector

## HC HANDLE OPTIONS



HCM and HC4 handle options

Developed to bring more of the controls closer to the operator, the HC range of hand grips can be specified with either a membrane keypad or up to six push button switches mounted in the front of the handle. Button layout and operating force have been selected so as to minimise the amount of thumb movement as well as the effort required to activate each operation.

The membrane keypad can accommodate an LED display and up to nine switches. The membrane keypads are available only to specific customer orders and are subject to individual design requirements and consequential availability.

Note: This handle option is not available with the L (Light) option Center Return Spring with the JC600

Specifications	HCO to HC6	HCM
Joystick Range	JC150, JC600	JC150, JC600
Maximum Height Above Flange	215mm	215mm
Maximum Width	46mm	46mm
Environmental Sealing (BSEN 60529)	IP65	IP65
Number of Switches	1 to 6	Keypad
Action	Momentary Button	Membrane Keypad
Switch Operating Force	3N	3.8N
Maximum Current @ 50Vdc	100mA	100mA
Expected Life (Operations)	100,000	1,000,000

Termination Details	HCO to HC6		HCM	
Joystick	JC150	JC600	JC150	JC600
Common Terminal	16	11		
N/O Contact Switch 1	3	1		
N/O Contact Switch 2	4	2		
N/O Contact Switch 3	5	3		
N/O Contact Switch 4	6	4		
N/O Contact Switch 5	7	5		
N/O Contact Switch 6	8	6		

Note: JC600 signals terminate on the 12 pin connector. Termination details for the HCM variant are dependent on the keypad's functionality.

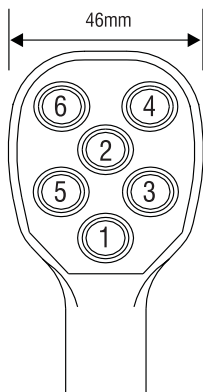

Order Code	Switches in positions					
HC0						
HC1		2				
HC2			3		5	
HC3	1		3		5	
HC4	1	2	3		5	
HC5		2	3	4	5	6
HC6	1	2	3	4	5	6
HCM	Handle with membrane keypad					

## HP/HS HANDLE OPTIONS



HS00 handle option

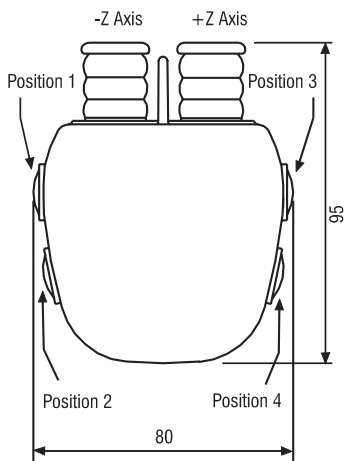

HP15 handle option

All dimensions in mm

Designed to be operated with the palm of the hand resting on the top of the handle, the HP/HS range features an additional axis of proportional control and up to six push buttons, mounted to the front and side of the handle.

Generating an analogue output proportional to the movement, the two linear potentiometers mounted at the front of the HP handle can be configured as the two halves of the Z-axis. In the HS handle these

are replaced by two momentary action push buttons. A further four buttons are mounted on either side of the handle according to the order code detailed below. Button layout and operating forces have been selected so as to minimise the amount of finger movement as well as the effort required to activate each operation.

Note: This handle option is not available with the L (Light) option Center Return Spring with the JC600

Specification	HP	HS
Joystick Range	JC150, JC600	JC150, JC600
Maximum Height Above Flange	144mm	144mm
Maximum Dimension	95mm	90mm
Environmental Sealing (BSEN 60529)	IP65	IP65
No of Switches	0 to 4	2 to 6
Action	Momentary Button	Momentary Button
Switch Operating Force	3N	3N
Maximum Current @ 50Vdc	100mA	100mA
Expected Life (Operations)	500,000	500,000

Third (Z) Axis	HP
Breakout Force	5N
Operating Force	10N
Mechanical Movement	10.5mm
Electrical Movement	10.0mm
Expected Life (Operations)	1 million
Maximum Load Current	See Design Note in rear of Joystick Controllers data sheet
Maximum Power Dissipation	0.25W @ 25°C
Track Resistance	1kΩ±20%
Output Voltage Range	0% to 100%Vs
Directional Switches	None

Order Code	Switches in position			
HP0	HS0			
HP1	HS1	1		
HP2	HS2		2	
HP3	HS3			3
HP4	HS4			4
HP5	HS5	1	2	
HP6	HS6	1		3
HP7	HS7	1		4
HP8	HS8		2	3
HP9	HS9		2	4
HP10	HS10		3	4
HP11	HS11	1	2	3
HP12	HS12	1	2	4
HP13	HS13	1		3
HP14	HS14		2	3
HP15	HS15	1	2	3

Termination Details	HP	HP	HS	HS
Joystick	JC150	JC600	JC150	JC600
Common Terminal for Switches	16	11	16	11
N/O Contact Switch 1	3	1	3	1
N/O Contact Switch 2	4	2	4	2
N/O Contact Switch 3	5	3	5	3
N/O Contact Switch 4	6	4	6	4
N/O Contact Front Left Switch			7	5
N/O Contact Front Right Switch			8	6
Positive supply to -Z Axes	2	8		
Positive supply to +Z Axes	2	7		
Zero or Negative supply to -Z Axes	15	12		
Zero or Negative supply to +Z Axes	15	10		
Output Voltage Signal from -Z Axes	7	5		
Output Voltage Signal from +Z Axes	8	6		

Note: JC600 signals terminate on the 12 pin connector

## WT/WN HANDLE OPTIONS



Designed to provide a simple approach to a Deadman's handle whilst offering the flexibility of multiple switches in the top of the handle, the 'W' range of ergonomic handgrips can be fitted to both the JC150 and JC600 range of joysticks.

The handle can be specified with (WT) or without (WN) the Deadman's trigger as well as up to four switches in the handle top. These can be specified to be in any of the four "on axis" positions.

### Specification

Joystick Range	JC150, JC600	
Maximum Height Above Flange	182mm	
Maximum Grip Diameter	40.5mm	
Environmental Sealing	IP66	BSEN60529
Number of Switches	0 to 5	
Action	Momentary Rocker or Trigger	
Switch Operating Force	5N at 11mm Radius (Rocker top switches) 3N at Center line of Deadman's Lever switch	
Maximum Current @ 30Vdc	100mA (Rocker top switches)	
Maximum Current @ 28Vdc	5A Resistive (Deadman's Lever-two wires connected)	
Expected Life	1 million cycles at full power (Rocker top switches) 100,000 cycles @5A Resistive (Deadman's Lever) 500,000 cycles @1A Resistive (Deadman's Lever)	
Operating Temperature Range	-40°C to +70°C	
Storage Temperature Range	-40°C to +80°C	

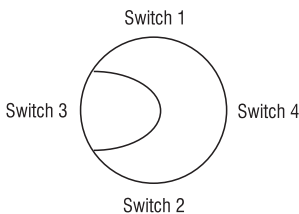
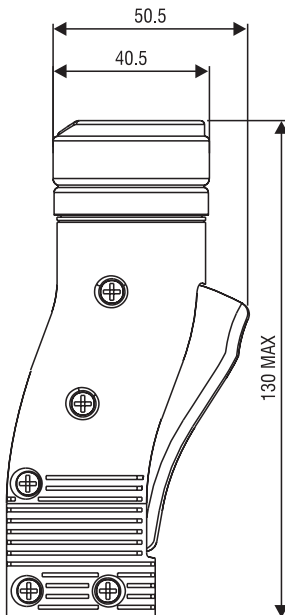

All dimensions in mm

### Termination Details

Joystick	JC150	JC600	Wire Color
Common Terminal- Rocker	16	11	Black
Switch Position 1	6	4	Blue
Switch Position 2	3	1	Green
Switch Position 3	8	6	Yellow/Red
Switch Position 4	7	5	Pink
Trigger Switch	4	2	Blue/Orange (Two Wires)
Trigger Switch	5	3	Yellow (Two Wires)

### Order Code

Order Code	Switches in position
WT00 WN00	
WT01 WN01	1
WT02 WN02	2
WT03 WN03	3
WT04 WN04	4
WT05 WN05	1 2
WT06 WN06	1 3
WT07 WN07	1 4
WT08 WN08	2 3
WT09 WN09	2 4
WT10 WN10	3 4
WT11 WN11	1 2 3
WT12 WN12	1 2 4
WT13 WN13	1 3 4
WT14 WN14	2 3 4
WT15 WN15	1 2 3 4

Note: Two switches can be operated by deflecting the handle top at 45°.

## A HANDLE OPTIONS



A2LD handle option

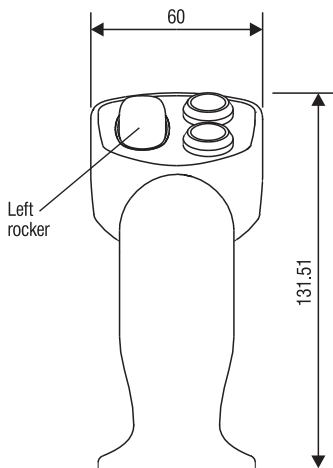
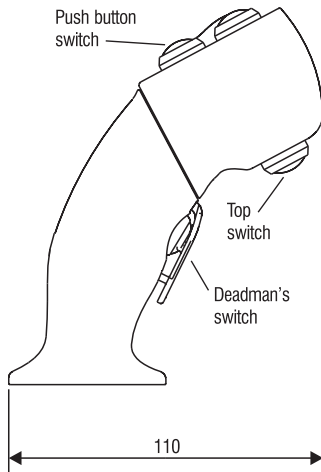

All dimensions in mm

Developed to meet the demands for more complex control systems in off-highway applications, the 'A' range of ergonomic hand grips can be fitted with a combination of analogue outputs, push button and deadman's switches.

The handle can be specified with two independent analogue outputs generated by proportional rockers which, in turn, provide an additional direction switch as well as the potentiometric output. When coupled with a two axis base joystick this unit can provide a 4 axis control device.

### Specification

Joystick Range	JC150, JC600
Maximum Height Above Flange	166mm
Maximum Grip Diameter	61mm
Environmental Sealing	IP65
Number of Switches	1 to 6
Action	Momentary Button
Switch Operating Force	3N
Maximum Current @ 50Vdc	200mA
Expected Life (Operations)	1,000,000

### Third Axes

Breakout Force	8.5N at the end of the rocker	
Operating Force	15N at the end of the rocker	
Mechanical Movement	$\pm 15^\circ$	Tolerance $\pm 1^\circ$
Electrical Movement	$\pm 10^\circ$	Tolerance $\pm 1^\circ$
Expected Life (Operations)	3 million	
Mass	170g - A2LD option	
Maximum Load Current	See Design Note in rear of Joystick Controllers data sheet	
Maximum Power Dissipation	0.25W at 25° C	
Track Resistance	Same as the Y axis track of the joystick to which it is fitted	
Output Voltage	Same as the Y axis track of the joystick to which it is fitted	
Center Tap Angle	$\pm 1.5^\circ$	Tolerance $\pm 1^\circ$
Directional or Center Off Switch	Standard	
Switch Gap	$\pm 2.5^\circ$	Tolerance $\pm 1^\circ$
Maximum Supply Voltage (Switch only)	35Vdc	

### Termination Details

Joystick	JC150	JC600
Common Terminal All Switches (including third axes)	16	11
N/O Switch 1	6	4
N/O Switch 2	5	3
N/O Switch 3	4	2
N/O Switch 4	3	1
Top Switch	7	5
Deadman's Switch	TBD	12 + 8
Left or horizontal rocker positive supply voltage	2	7
Left or horizontal rocker center tap	8	6
Left or horizontal rocker zero or negative supply voltage	15	10
Left or horizontal rocker output voltage signal	7	5
N/O signal left rocker forward	4	2
N/O signal left rocker backward	3	1
N/O signal horizontal rocker right	3	1
N/O signal horizontal rocker left	6	4
Right rocker positive supply voltage	2	7
Right rocker center tap	8	6
Right rocker zero or negative supply voltage	15	10
Right rocker output voltage signal	TBD	9
N/O signal right rocker forward	5	3
N/O signal right rocker backward	6	4

Not all termination details can be shown for A handle options. Termination details to be advised on ordering.

## A HANDLE OPTIONS

A maximum of 8 switches can be mounted in the handle with 6 switches in the top plate for thumb actuation, one positioned for index finger actuation and a switch fitted with an additional deadman's lever.

Functionality	Rockers			Switches							
	Left	Right	Horizontal	1	2	3	4	5	6	Top	Deadman's
Left Rocker		✓		✓	✓			✓		✓	✓
Right Rocker	✓					✓	✓		✓	✓	✓
Horizontal rocker				✓	✓						✓
Switch 1	✓			✓	✓	✓	✓	✓	✓	✓	✓
Switch 2	✓		✓	✓		✓	✓	✓	✓	✓	✓
Switch 3		✓	✓	✓	✓		✓	✓	✓	✓	✓
Switch 4		✓		✓	✓	✓		✓	✓	✓	✓
Switch 5	✓			✓	✓	✓	✓		✓	✓	✓
Switch 6		✓		✓	✓	✓	✓	✓	✓		✓
Top Switch	✓	✓		✓	✓	✓	✓	✓	✓		✓
Deadman's Switch	✓	✓	✓	✓	✓	✓	✓	✓	✓	✓	✓

**ORDER CODE**

A - 0 - 0 - 0

Push button \_\_\_\_\_

Rocker Position \_\_\_\_\_

Additional Switches \_\_\_\_\_

**Push button**

No. of switches 1 to 6 switches in the top plate

**Rocker Position**

	0	L	R	B	H
	None	Left	Right	Both	Horizontal

**Additional Switches**

	0	T	D	B
	None	Top	Deadman's	Both

### Handle front plate diagram

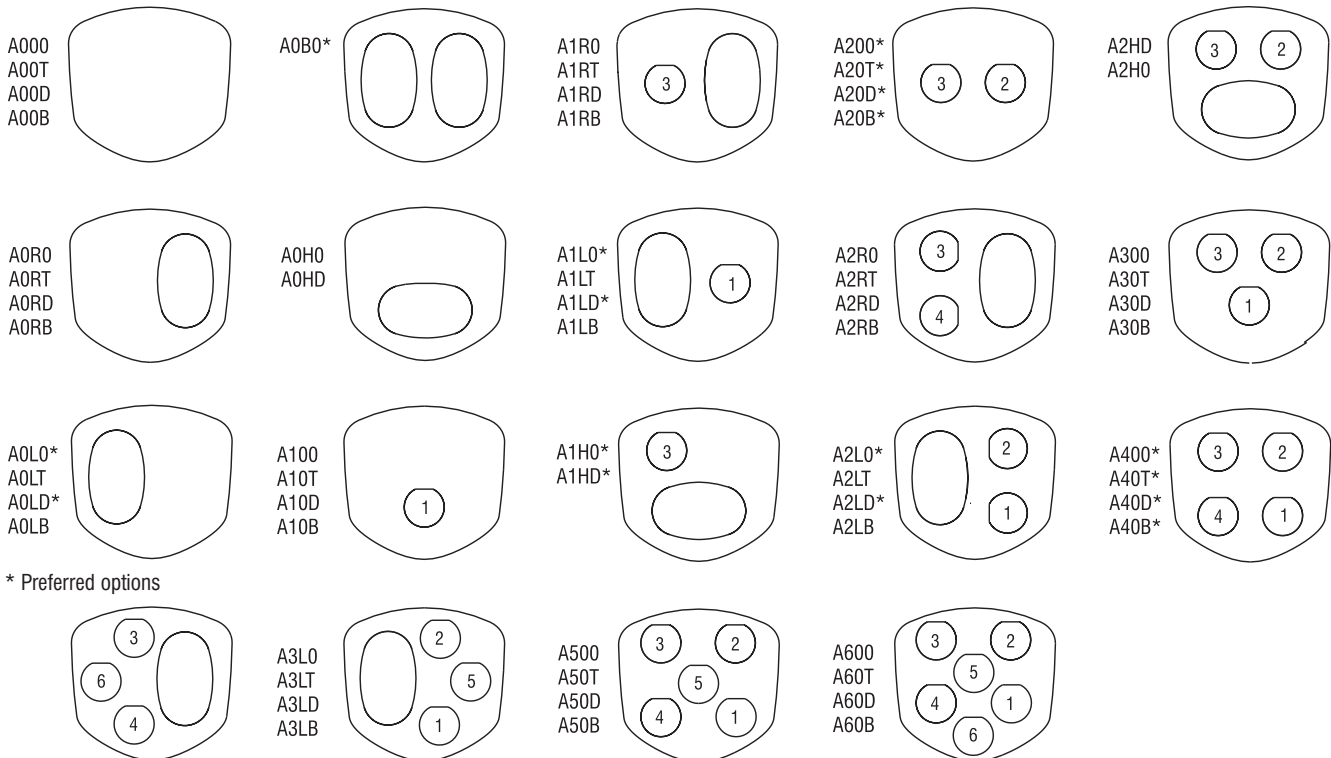

Options on longer lead-time Termination details to be advised on ordering

## TR HANDLE OPTIONS



TR2 handle option

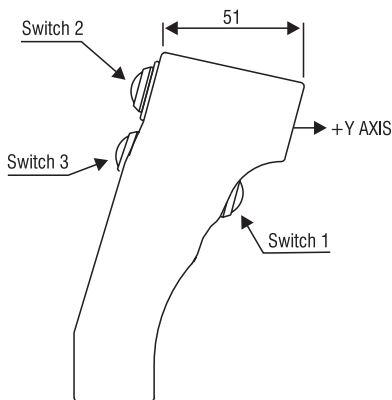

All dimensions in mm

Replicating the ergonomic controls found in aerospace applications, the TR range of hand grips features a button to the front and up to two buttons to the rear. The profile of these handles ensures that the operator's fingers are permanently close to all buttons, the operating force of which has been selected to minimise operator fatigue.

Specification	TR0	TR1	TR2	TR3
Joystick Range	JC150, JC600	JC150, JC600	JC150, JC600	JC150, JC600
Maximum Height Above Flange	176mm	176mm	176mm	176mm
Environmental Sealing (BSEN 60529)	IP65	IP65	IP65	IP65
Number of Switches	0	1	2	3
Action		Momentary Button	Momentary Button	Momentary Button
Operating Force		3N	3N	3N
Maximum Current @ 30Vdc		100mA	100mA	100mA
Expected Life (Operations)		100,000	100,000	100,000

Termination Details	TR1 to TR3	
Joystick	JC150	JC600
Common Terminal Switch 1	15	12
N/O Contact Switch 1	3	1
Common Terminal Switch 2	16	11
N/O Contact Switch 2	4	2
Common Terminal Switch 3	15	10
N/O Contact Switch 3	5	3

Note: JC600 signals terminate on the 12 pin connector

Order Code	Switch Position		
TR1	1		
TR2	1	2	
TR3	1	2	3

## ZA/ZAS HANDLE OPTIONS



ZA handle

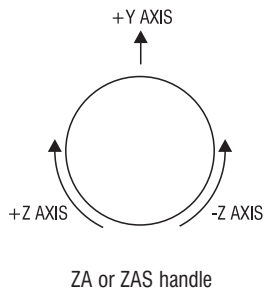

ZA or ZAS handle

Developed to move in the same plane as the equipment that they are controlling, the ZA and ZAS fingertip handles feature an additional axis of proportional/switched control.

Rotating horizontally about their center, the ZA handles generate both analogue and/or switched reference signals proportional to the direction and distance in which they are turned. The handles have an expected life in excess of 500,000 operations.

Specification	ZA	ZAS
Joystick Range	JC300, JC400	JC300, JC400
Maximum Height Above Flange	80mm	80mm
Maximum Diameter	39mm	39mm
Environmental Sealing (BSEN 60529)	IP65	IP65
<b>Third (Z) Axis</b>	Rotary	Rotary
Breakout Torque/Force	0.1Nm	0.1Nm
Operating Torque/Force	0.3Nm	0.3Nm
Maximum Operating Torque	1Nm	1Nm
Expected Life (Operations)	1 million	1 million
Mechanical Angle	±29°	±29°
Electrical Angle	±27°	
<b>Analogue Track</b>	Yes	No
Track Resistance	2k7Ω ±20%	
Output Voltage Range	7% to 93% ±1%	
Center Tap Voltage (1MΩ load)	50% ±3%	
Center Tap Angle	±2.5°	
Maximum Load Current	See Design Note in rear of Joystick Controllers data sheet	
Maximum Power Dissipation	Directional switches – 200mA Resistive 0.25W @ 25° C	
<b>Directional Switch</b>	Yes	Yes
Switch Operating Angle	±4° ±1°	±20° ±2°
Maximum Load Current	1 mA	1 mA
Maximum Supply Voltage (Vs)	35Vdc	
<b>Termination Details</b>	<b>ZA or ZAS</b>	
Joystick	JC300	JC300, JC400
	<b>Terminal</b>	<b>Wire Color</b>
Z-axis positive supply voltage	17	Yellow/Red
Z-axis negative or zero supply voltage	18	Violet
Z-axis output voltage signal	19	Pink
Z-axis center tap	20	Blue
N/O signal indicating handle movement in the +Z axis	21	Yellow/Black
N/O signal indicating handle movement in the -Z axis	22	White/Red
Common terminal for +Z axis switch track	23	Red/Blue

## ZC/ZCS HANDLE OPTIONS



ZC or ZCS handle option

The convex profile of the top of ZC handle has been designed to allow for thumb control of the JC300 and JC400 range of joysticks. Your company logo can be accommodated on the top of the ZC handle. The deadman's button inside the ZCS handle can be used to verify the change in signals from the joystick, so increasing the integrity of your control system

Specification	ZC	ZCS
Joystick Range	JC300, JC400	JC300, JC400
Maximum Height Above Flange	70mm	73mm
Maximum Diameter	23mm	23mm
Environmental Sealing (BSEN 60529)	IP65	IP65
Number of switches	0	1
Action		Momentary button
Operating Force		7Nm
Maximum Current @ 30Vdc		100mA
Expected Life (Operations)		500,000
Termination Details	ZCS	
Joystick	JC300, JC400	
	Terminal	Wire Color
Common Terminal Switch 1	5	Red/Green
N/O Contact Switch 1	15	White/Black

## KW/KWS HANDLE OPTION



KWS handle

Developed to allow full grip use of the smaller joysticks, it is fitted with (KWS) or without (KW) push button switch in the top of the handle within easy reach of the operator's thumb. This button can be used, as in a deadman's function, to verify the change in signals from the joystick, so increasing the integrity of your control system.

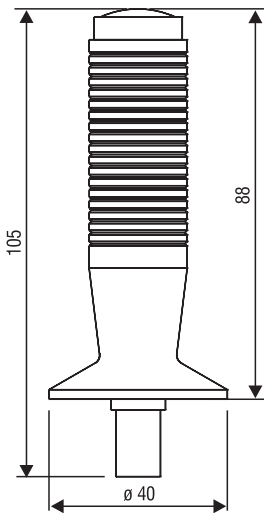

All dimensions in mm

Specification	KW	KWS
Joystick Range	JC300, JC400	JC300, JC400
Maximum Height Above Flange	130mm	130mm
Maximum Grip Diameter	22mm	22mm
Environmental Sealing	IP65	IP65
Number of Switches	0	1
Action		Momentary Button
Switch Operating Force		3N
Maximum Current @ 50Vdc		100mA
Expected Life (Operations)		50,000

Termination Details		
Joystick	JC300	JC300, JC400
	<b>Terminal</b>	<b>Wire Color</b>
Common Terminal Switch	5	Red/Green
Switch	15	White/Black

Penny + Giles quality systems meet the requirements of ISO9001, the Civil Aviation Authority and numerous customer's certification standards.

Quality is at the heart of all our systems ensuring the reliability of our products from initial design to final despatch.



## Available from Penny + Giles

A wide range of instrumentation for measurement and control solutions in industrial and aerospace applications. Please ask for more details.



- VRVTs
- LVDTs - industrial/aerospace
- Hybrid Linear Potentiometers
- Solenoids
- Rotary Potentiometers
- Joystick Controllers
- In-Cylinder Transducers

## Contact Worldwide

### WEB SITE

[www.pgcontrols.com](http://www.pgcontrols.com)

### UNITED KINGDOM

**Penny + Giles Controls Ltd**  
 36 Nine Mile Point Industrial Estate  
 Cwmfelinfach  
 Gwent NP11 7HZ UK  
 Telephone: +44 (0)1495 202000  
 Fax: +44 (0)1495 202006  
 e-mail: [sales@pgcontrols.com](mailto:sales@pgcontrols.com)

### USA

**Penny & Giles Controls Inc**  
 1100 East Woodfield Road,  
 Suite 140, Schaumburg  
 IL 60173-5116  
 Telephone: +1 847 995 0840  
 Fax: +1 847 995 0838  
 e-mail: [penny\\_giles\\_sch@compuserve.com](mailto:penny_giles_sch@compuserve.com)

### GERMANY

**Penny & Giles**  
**Zweigniederlassung der Bowthorpe GmbH**  
 Straussenlettenstr. 7b  
 85053 Ingolstadt  
 Telephone: +49(0)841 61000  
 Fax: +49(0)841 61300  
 e-mail: [penny-giles@t-online.de](mailto:penny-giles@t-online.de)

**Penny + Giles products  
 are in service with  
 these industries  
 throughout the world.**

**Aerospace  
 Automotive  
 Construction  
 Defence**

**Leisure  
 Marine  
 Material handling  
 Mining**

**Motorsport  
 Off-highway  
 Petrochemical  
 Plastics and Rubber**

**Power generation  
 Process control  
 Transportation  
 Timber and Forestry**

The information contained in this brochure on product applications should be used by customers for guidance only. Penny & Giles Controls Ltd makes no warranty or representation in respect of product fitness or suitability for any particular design application, environment, or otherwise, except as may subsequently be agreed in a contract for the sale and purchase of products. Customer's should therefore satisfy themselves of the actual performance requirements and subsequently the products suitability for any particular design application and the environment in which the product is to be used.

Continual research and development may require change to products and specification without prior notification. All trademarks acknowledged



A SPIRENT Company

© Penny & Giles Controls Ltd. 2000