



aerospace
climate control
electromechanical
filtration
fluid & gas handling
hydraulics
pneumatics
process control
sealing & shielding



Electronic Control Systems Sensors

FP2000 Ferrous Proximity Sensor



ENGINEERING YOUR SUCCESS.

Application

The FP2000 sensor belongs to the Parker family of accessories provided to complement electronic control systems. The FP2000 is a ferrous proximity sensor for mobile hydraulic applications and will sense ferrous objects. The sensor has twelve inch leads with an attached Deutsch connector. To make the sensor suitable for mobile equipment, we have focused upon properties such as reliability and ease of installation.

Properties

Reliability

The FP2000 has a glass-filled nylon plastic construction for strength and corrosion resistance. The sensor uses non-contact technology, through the use of an internal reed switch, for trouble free operation. The sensor is very robust and able to withstand rugged applications.

Installation

The FP2000 is well designed for the mobile hydraulics industry. The 2 pin connector is a sealed Deutsch DTM type designed for automotive use. This connector combined with potted electronics gives the sensor excellent protection for exposed outdoor applications. The mounting holes are extra large for easy alignment. These features provide for easy installation and removal, even in field conditions.

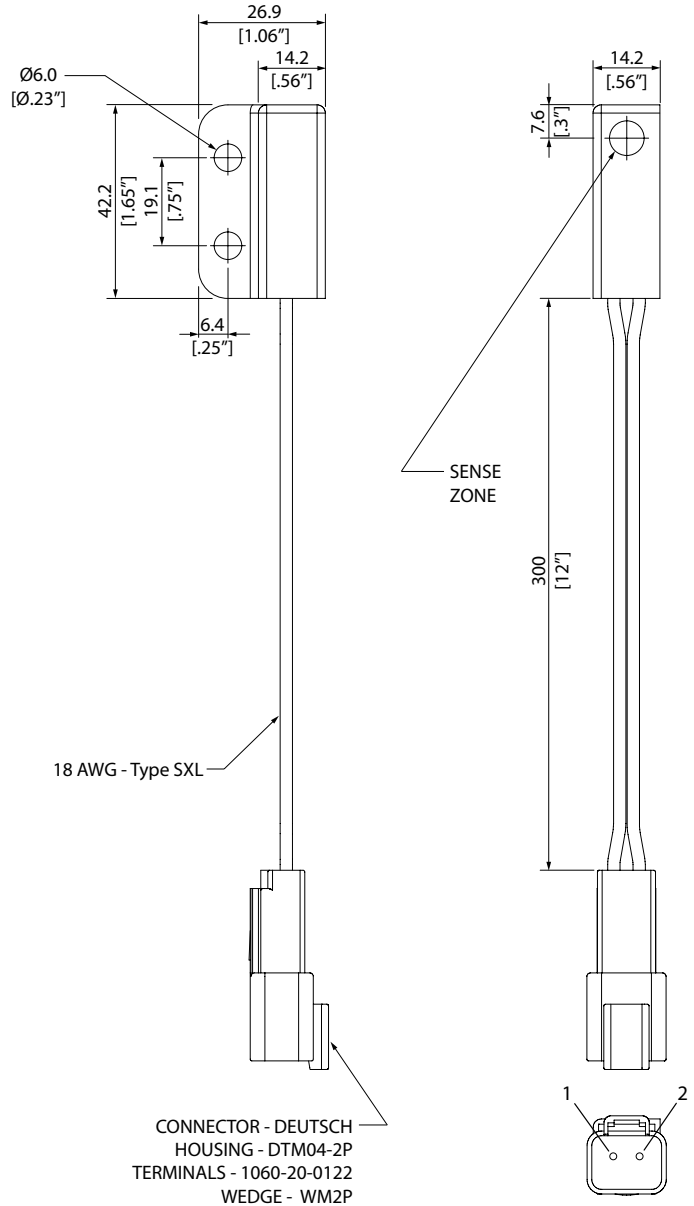

General

Weight 24 g
 Temperature range -40°C to 105°C
 Operating life 10 million cycles
 (at logic load)
 Airgap “make” (signal high) Min 5.1 mm [0.2”]
 Airgap “break” (signal low) Max 11.4 mm [0.45”]

Mechanical characteristics

Switch type Normally open
 Connector Deutsch DTM

Electrical characteristics

Contact resistance (initial) Max 200 mΩ
 Breakdown voltage Min 200 VDC
 Switching voltage Max 100 VAC/VDC
 Switching current DC Max 300 mA
 Bounce time Max 0.4 ms

Ordering part number

FP2000 01695

Environmental protection

Mechanical

Shock 1m drop
 Vibration 30 Gs

Climate

Sealing IP6K9K

Chemical environment

Liquids (resistance) standard automotive



WARNING - USER RESPONSIBILITY

FAILURE OR IMPROPER SELECTION OR IMPROPER USE OF THE PRODUCTS DESCRIBED HEREIN OR RELATED ITEMS CAN CAUSE DEATH, PERSONAL INJURY AND PROPERTY DAMAGE.

- This document and other information from Parker-Hannifin Corporation, its subsidiaries and authorized distributors provide product or system options for further investigation by users having technical expertise.
- The user, through its own analysis and testing, is solely responsible for making the final selection of the system and components and assuring that all performance, endurance, maintenance, safety and warning requirements of the application are met. The user must analyze all aspects of the application, follow applicable industry standards, and follow the information concerning the product in the current product catalog and in any other materials provided from Parker or its subsidiaries or authorized distributors.
- To the extent that Parker or its subsidiaries or authorized distributors provide component or system options based upon data or specifications provided by the user, the user is responsible for determining that such data and specifications are suitable and sufficient for all applications and reasonably foreseeable uses of the components or systems.

OFFER OF SALE

Please contact your Parker representative for a detailed "Offer of Sale".

Sales Offices Worldwide

North America

Hydraulics Group Headquarters
6035 Parkland Boulevard
Cleveland, OH 44124-4141 USA
Tel: 216-896-3000
Fax: 216-896-4031

**Parker Hannifin Canada
Motion & Control Division – Milton**
160 Chisholm Drive Milton
Ontario Canada L9T 3G9
Tel: 905-693-3000
Fax: 905-876-1958

**Mexico
Parker Hannifin de México**
Av eje uno norte num 100
Parque Industrial Toluca 2000
Toluca, Mex C.P. 50100
Tel: 52 722 2754200
Fax: 52 722 2799308

Europe

**Europe Hydraulics Group
Parker Hannifin Corporation**
Parker House
55 Maylands Avenue
Hemel Hempstead, Herts
HP2 4SJ England
Tel: 44 1442 458000
Fax: 44 1442 458085

Latin America

**Brazil
Hydraulics Division
Parker Hannifin Ind. e Com. Ltda**
Av. FredericoRitter, 1100
Cachoeirinha RS, 94930-000 Brazil
Tel: 55 51 3470 9144
Fax: 55 51 3470 3100

Mobile Sales

**Mobile Sales Organization
and Global Sales**
595 Schelter Road
Suite 100
Lincolnshire, IL 60069 USA
Tel: 847-821-1500
Fax: 847-821-7600

Industrial Sales

Great Lakes Region
3700 Embassy Parkway
Suite 260
Fairlawn, OH 44333 USA
Tel: 330-670-2680
Fax: 330-670-2681

Southern Region
1225 Old Alpharetta Road
Suite 290
Alpharetta, GA 30005 USA
Tel: 770-619-9767
Fax: 770-619-9806

Chicago Region
1163 E. Ogden Avenue
Suite 705, #358
Naperville, IL 60563 USA
Tel: 630-964-0796
Fax: 866-473-9274

Pacific Region
8460 Kass Drive
Buena Park, CA 90621
Tel: 714-228-2510
Fax: 714-228-2511

Eastern Region
100 Corporate Drive
Lebanon, NJ 08833 USA
Tel: 908-236-4121
Fax: 908-236-4146

Asia Pacific

**Asia Pacific Headquarters
Parker Hannifin Hong Kong Ltd**
8/F, Kin Yip Plaza
9 Cheung Yee Street
HK-Cheung Sha Wan, Hong Kong
Tel: 852 2428 8008
Fax: 852 2425 6896

**Australia Headquarters
Parker Hannifin Pty Ltd.**
9 Carrington Road
Castle Hill, NSW 2154, Australia
Tel: 612 9634 7777
Fax: 612 9842 5111

**China Headquarters
Parker Hannifin Motion & Control
(Shanghai) Co., Ltd**
280 Yunqiao Road,
Jin Qiao Export Processing Zone
CN-Shanghai 201206, China
Tel: 86 21 5031 2525
Fax: 86 21 5834 3714

**Korea Headquarters
Parker Hannifin Korea Ltd**
6F Daehwa Plaza
169 Samsung-dong, Gangnam-gu
KR-Seoul, 135-090, Korea
Tel: 82 2 559 0400
Fax: 82 2 556 8187

**South Africa
Parker Hannifin Africa Pty Ltd
Parker Place**
10 Berne Avenue Airport
P.O. Box 1153
ZA-Kempton Park 1620,
Republic of South Africa
Tel: 27 11 961 0700
Fax: 27 11 392 7213

